

PARTITION SENSOR WIRING

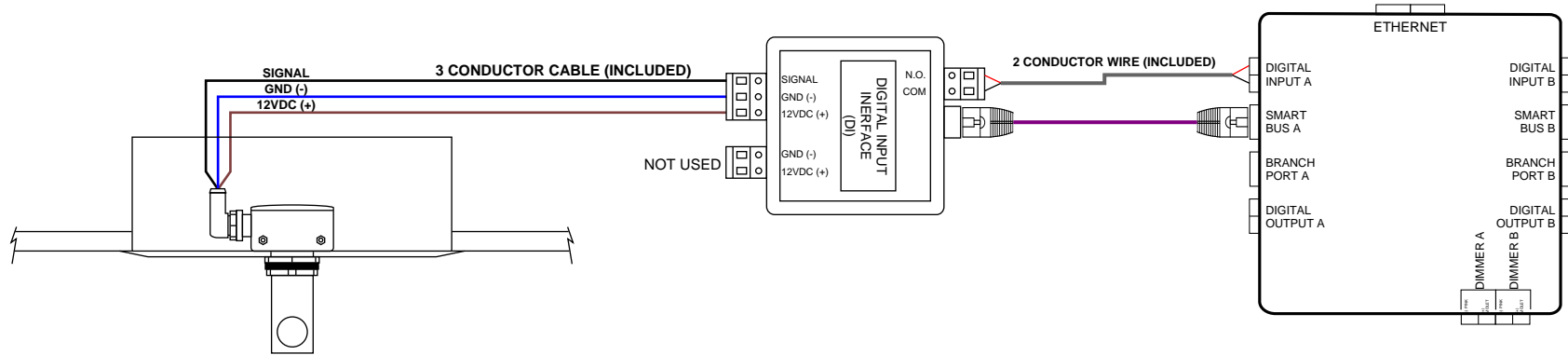

SYMBOLS AS SHOWN ON SUBMITTAL AND CONSTRUCTION DOCUMENTS



CABLE TYPES			
LINE ID	DESCRIPTION	TYPE	NOTES
—	SMART	CAT 5 (MIN)	TOTAL SMARTNET LENGTH NOT TO EXCEED 400'

TIPS / NOTES

- ONCE DIGITAL INPUT INTERFACE (DI) IS POWERED ON VIA THE SMARTNET, THE PARTITION SENSOR AND DI CAN BE TESTED.
- IF WIRED CORRECTLY THE PARTITION SENSOR WILL HAVE A VISIBLE RED LED.
- THE REFLECTOR CAN THEN BE MOVED IN FRONT OF THE SENSOR. THIS SHOULD CAUSE AN AUDIBLE CLICK INSIDE THE DI. IF CLICK IS NOT HEARD, VERIFY WIRING.
- PARTITION SENSOR ONLY FUNCTIONS WITH THE ROOM MANAGER.

PARTITION SENSOR MOUNTING

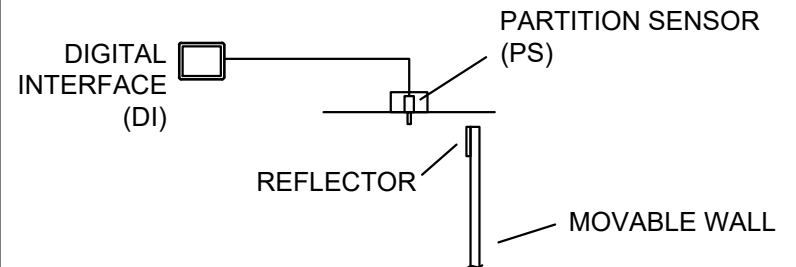

- PARTITION SENSOR MUST BE IN LINE WITH REFLECTOR AND WITHIN 10' OR LESS